

7.4



TOOLS FOR CONSTRUCTION & FOR WOOD

建筑工具、木工工具

ACO offers a wide range of tile cutters designed for straight, angular and circular ceramic cuts up to 120cm wide.
奥戈工具提供多种多样的瓷砖切割机，专门为建筑业而设计，直线形的、带角度的、圆形的，可切割宽达120厘米的瓷砖。

All of them equipped with tubular or solid guides for accurate and professional cuts, and provided with a nylon bag for their easy transport.
所有工具都带有直管或固态波导设计，进行精确、专业的切割；并备有尼龙袋，便于携带。

0. Designed for straight and angular ceramic cutting up to 120cm.
专业设计，要对宽达120厘米的瓷砖进行直线的、带角度的、圆形的切割。

2. Adjustable bearings for accurate cutting.
可调轴，精确切割。

4. Swivel square set with metric scale and angular measuring system for 0° to 45° straight cutting.
带有公制标尺的旋转装置，加上角度测量系统，能轻松进行0°到45°的直线切割。

1. One solid steel guide for better view of the scrapping and cutting process.
不锈钢波导，能更好地控制刨切过程。

3. Side stop for repetitive straight and 45° cutting.
侧面限锁按钮，便利的直线形或45度角的重复切割。

5. Aluminium base with movable large extension pads to stand larger ceramic sizes.
铝座配有活动延长板，可承托面积更大的瓷砖。

6. Cushion effect base to get highest accuracy cuts.
专业垫座，能保证最精确的切割。

7. Ergonomic handle for easy gripping and comfortable use.
人体工程学手柄，更易抓牢，舒适好用。

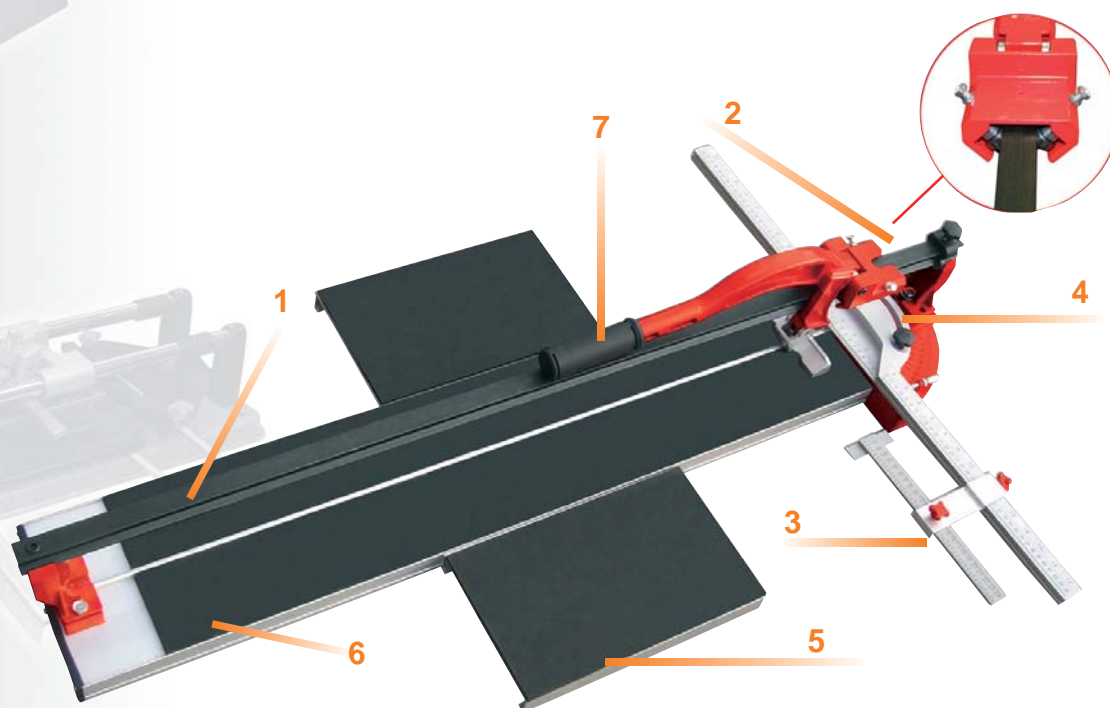

7.4 TOOLS FOR CONSTRUCTION & FOR WOOD 建筑工具、木工工具



HAND TILE CUTTERS / 手动砖瓦切割机

CLASSIC

订货号 COD	切割宽度	切割厚度	便携式包装	Kg.	碳钨合金切割轮
3230611	40cm	4-12mm	●	4,0	3238003 Ø22x6x2mm
3230612	60cm			5,0	

Technical specification / 技术规格

Rectified and chromed steel tubular guides / 精制镀铬不锈钢波导

Adjustable breaking system / 可调刹制系统

Base with cushion effect / 机座缓冲垫效果

Direct view of scrapping and cutting process / 直线导视切割过程

Side limit for repetitive straight and 45° cuts / 侧面限定系统, 确保了直线和45度的反复切割

Tungsten carbide cutting wheel (WIDIA) / 碳钨硬质合金切割轮 (WIDIA)



订货号 COD	切割宽度	切割厚度	圆形切割直径	便携式包装	Kg.	碳钨合金切割轮
3230613	40cm	4-12mm	30-80mm	●	5,0	3238003 Ø22x6x2mm

Technical specification / 技术规格

Rectified and chromed steel tubular guides / 精制镀铬不锈钢波导

Adjustable breaking system / 可调刹制系统

Base with cushion effect / 机座缓冲垫效果

Direct view of scrapping and cutting process / 直线导视切割过程

Side limit for repetitive straight cuts / 侧面限定系统, 确保了直线的反复切割

Angular measuring system for 0 to 45° straight cutting / 角度测量系统, 确保了0度到45度的直线切割

Drill hole for circular cutting / 钻孔, 便于圆形切割

Tungsten carbide cutting wheel (WIDIA) / 碳钨硬质合金切割轮 (WIDIA)



MASTER

COD	切割宽度	切割厚度	便携式包装	Kg.	碳钨合金切割轮
3230711	60cm	≤ 16mm	●	14	3238007 Ø20x14x6mm
3230712	70cm			15	
3230713	80cm			16	
3230714	90cm			17	
3230715	100cm			18	
3230716	120cm			20	

Technical specification / 技术规格

Rectified and chromed steel solid guides / 精制镀铬不锈钢波导

Adjustable breaking system / 可调刹制系统

Base with cushion effect / 机座缓冲垫效果

Direct view of scrapping and cutting process / 直线导视切割过程

Side limit for repetitive straight and 45° cuts / 侧面限定系统, 确保了直线和45度角的反复切割

Swivel square set with metric scale and angular measuring system for 0 to 45° straight cutting
带有公制标尺的旋转装置, 加上角度测量系统, 能轻松进行0°到45°的直线切割

Aluminium base with movable large extension pads for support of the larger tile sizes
铝座配有活动延长板, 可承托面积更大的瓷砖

Titanium (TiN) coated tungsten carbide (WIDIA) cutting wheel
镀钛 (TiN) 碳钨硬质合金切割轮 (WIDIA)



7.4 TOOLS FOR CONSTRUCTION & FOR WOOD

建筑工具、木工工具

SHOVELS / 钢铲

COD	L	A	B	Kg.	
3230811	1020	265	325	1,9	6
3230812		285	335	1,9	

COD	L	A	B	Kg.	
3230813	1020	250	325	2,1	6
3230814		265	340	2,1	

ALUMINIUM / 铝制铲

COD	L	A	B	Kg.	
3230815	1300	345	390	1,6	6

COD	L	A	B	Kg.	
3230816	990	260	305	0,9	6

COD	L	A	B	Kg.	
3230817	955	160	260	1,7	6

COD	L	A	B	Kg.	
3230818	1010	150	240	1,7	6

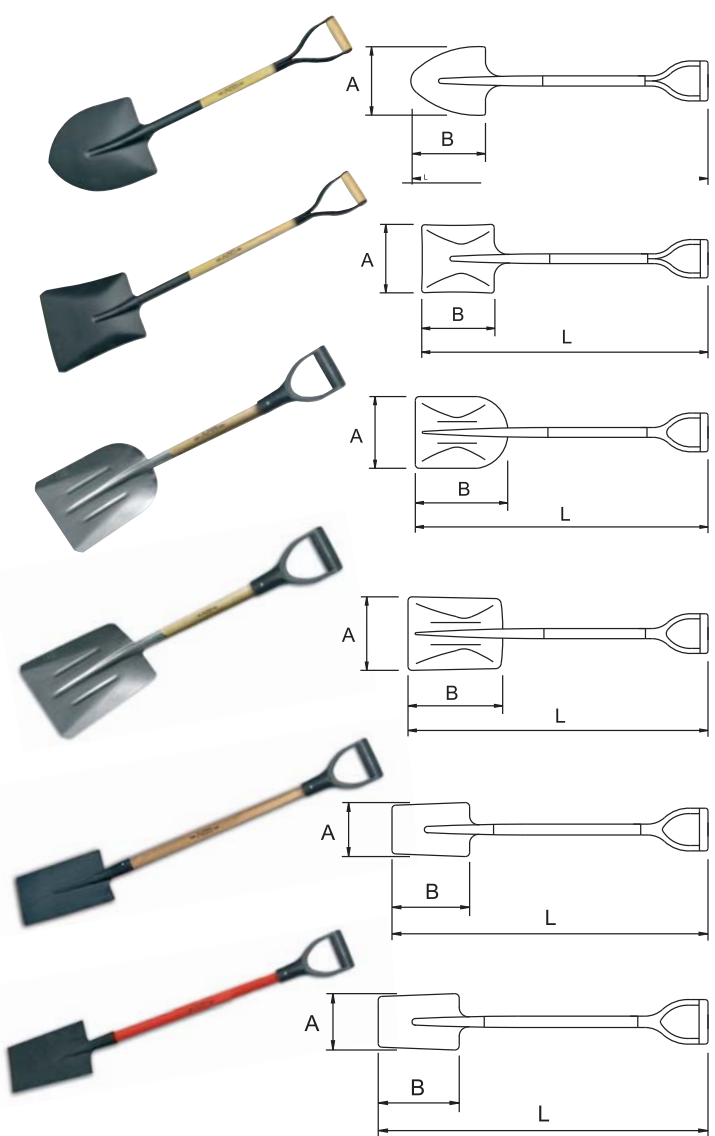

BRICKLAYERS / 砌砖刀

ALLOY STEEL BLADE, BOUBLE POLISHED AND HARDENED. VARNISHED HANDLE.
 钢合金刀刃、双打磨抛光和加硬、涂漆手柄

COD	A	B	gr.		
3230900	50	105	120	6	1
3230901	70	130	135		

COD	A	B	gr.		
3230902	50	105	120	6	1
3230903	70	130	135		

COD	A	B	C	gr.		
3230904	87	180	115	340	6	1

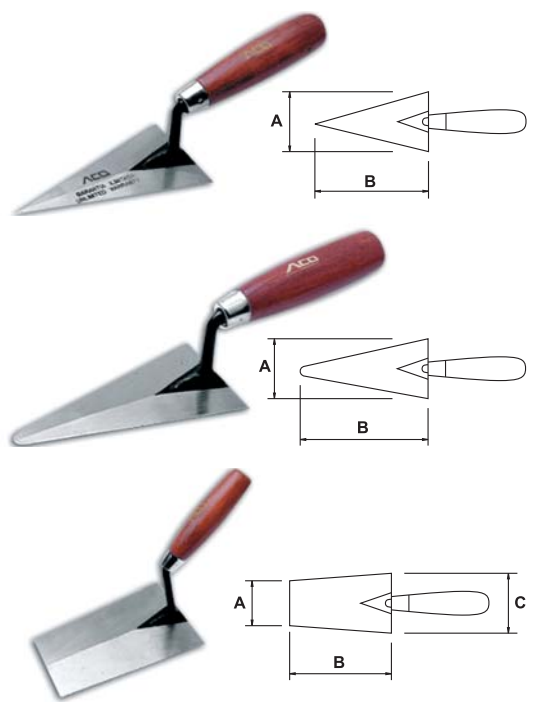

7.4

TOOLS FOR CONSTRUCTION & FOR WOOD

建筑工具、木工工具



MOD. CATALÁN 加泰罗尼亚 风格

COD	A	B	gr.		
3230905	115	160	310	6	1
3230906	122	170	320		

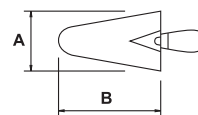

MOD. MADRID 马德里 风格

COD	A	B	gr.		
3230907	70	150	150	6	1
3230908	85	165	175		
3230909	95	180	200		
3230910	105	200	245		
3230911	115	230	290		

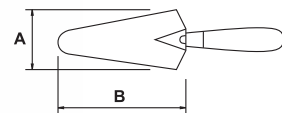

MOD. SEVILLA 塞维利亚 风格

COD	A	B	C	gr.		
3230912	85	190	112	320	6	1

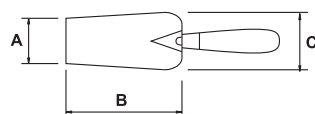

MOD. ARABIA 阿拉伯 风格

COD	A	B	C	gr.		
3230913	44	180	95	210	6	1
3230914	50	200	110	250		

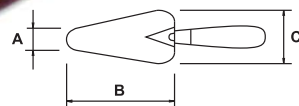

MOD. ALICATADOR 瓦工 模型

COD	A	B	C	gr.		
3230915	65	120	120	280	6	1

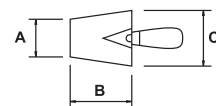

MOD. PORTUGAL 葡萄牙 风格

COD	A	B	C	gr.		
3230916	65	250	130	280	6	1

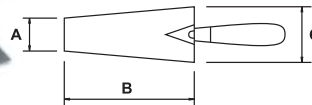

COD	A	B	C	gr.		
3230917	56	220	120	390	6	1
3230918	60	250	130	480		

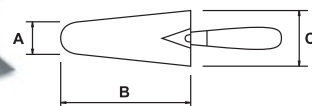

COD	A	B	gr.		
3230919	150	300	500	5	1

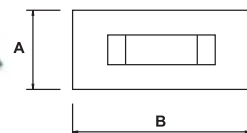

7.4 TOOLS FOR CONSTRUCTION & FOR WOOD 建筑工具、木工工具

批灰刀

COD	A	B	gr.		
3230920	115	275	400	5	1

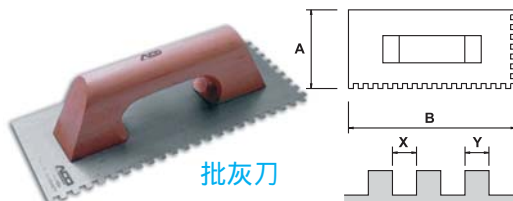

批灰刀

刮刀

3230921	30				
3230922	40	230	65		
3230923	50				
3230924	60			12	
3230925	70	235	75		1
3230926	80				
3230927	90	240	85		
3230928	100	250	90		

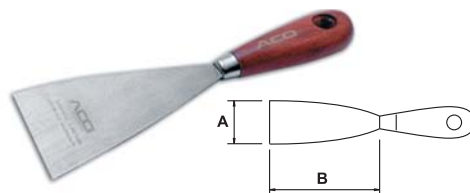

KIT 64 PCS. 刮刀组套 64件

COD	L mm	PCS.
3230929	30	8 (每种刀刃8件, 共64件)
	40	
	50	
	60	
	70	
	80	
	90	
	100	



PRY BAR / 撬棒

COD	size	L mm	Kg.	
3231011	6"	150	0,1	6
3231012	12"	300	0,2	
3231013	16"	405	0,5	
3231014	20"	490	0,8	
SET 撬棒套件		Composition/ 包括		
3231015	3231011,3231012, 3231013,3231014		1.6	1



WRECKING BAR / 撬拔棒

COD	L	mm	gr.
3231016	12"	14	250
3231017	18"	16	700
3231018	24"		1400
3231019	30"	18	2000
3231020	36"		2400
3231021	42"	19	2750
3231022	48"		3100



DRILLS / 电动强力旋转切割钻

(切割钻标配交货不含切割轮, 需单独购买。)

PERFORMATIC - 80

电动强力旋转切割钻 (最大切割直径80毫米)

订货号 COD	切割直径 CAP Ø	额定功率 W	电压 V	*R R	回转数/分钟 R.P.M.	Kg.
3231201	12-80	1500	230	1/2" BSP	950-2100	7,5
3231202			110	1.1/4" UNC		

* 1/2": Female / 母 - 1.1/4": Male / 公

SSR: Soft start system / 软启动系统



CE *G12

PERFORMATIC - 102

COD	CAP Ø	W	V	*R	R.P.M.	Kg.
3231203	12-102	1500	230	1/2" BSP	950-2100	22
3231204			110	1.1/4" UNC		

* 1/2": Female / 母 - 1.1/4": Male / 公

SSR: Soft start system / 软启动系统

PRCD: Included / 已包含 (To avoid voltage picks / 避免高压)

(切割钻应用: 混凝土、砖墙、水泥墙、沥青等。)



CE *G12

7.4 TOOLS FOR CONSTRUCTION & FOR WOOD 建筑工具、木工工具

电动强力旋转切割钻 带移动轮

PERFORMATIC - 205

订货号 COD	切割直径 CAP Ø	额定功率 W	电压 V	*R *R	回转数/分钟 R.P.M.	L	L	真空座 Kg.
3231205	12-205	2400	230	1/2" BSP 1.1/4" UNC	600	●	●	41
3231206						●	●	
3231207						●	●	
3231208			●			●		
3231209			●			●		
3231210			●			●		
3231211	110					●	●	
3231212						●	●	

* 1/2": Female / 母 - 1.1/4": Male / 公 PRCD: Included / 已包含 (To avoid voltage picks / 避免高压)
 L Fixed bracket / 固定托架 L 90° reclining bracket / 90°斜倚托架 Vacuum base / 真空座

PERFORMATIC - 255

订货号 COD	切割直径 CAP Ø	额定功率 W	电压 V	*R *R	回转数/分钟 R.P.M.	L	L	真空座 Kg.
3231213	12-255	2600	230	1/2" BSP 1.1/4" UNC	460-900	●	●	45
3231214						●	●	
3231215						●	●	
3231216			●			●		
3231217			●			●		
3231218			●			●		
3231219	110					●	●	
3231220						●	●	

PERFORMATIC - 300

订货号 COD	切割直径 CAP Ø	额定功率 W	电压 V	*R *R	回转数/分钟 R.P.M.	L	L	真空座 Kg.
3231221	12-300	3300	230	1/2" BSP 1.1/4" UNC	460-900	●	●	50
3231222						●	●	
3231223						●	●	
3231224			●			●		
3231225			●			●		
3231226			●			●		
3231227	110					●	●	
3231228						●	●	

* 1/2": Female / 母 - 1.1/4": Male / 公 PRCD: Included / 已包含 (To avoid voltage picks / 避免高压)



SINTERED DIAMOND DRILLS FOR REINFORCED CONCRETE DRILLS

加强型电动超强力混凝土旋转切割钻 烧结金刚石切割刀

FOR WET CUT / 金刚石切割刀 (加湿切割使用)

(推荐使用湿割刀, 防止过热。)

A	Ø x L	R	B	Ø x L	R
3231229	32x360	1.1/4" UNC FEMALE 母	3231151	12x120	1/2" BSP MALE 公
3231230	44x360		3231152	18x220	
3231231	53x360		3231153	26x320	
3231232	63x360		3231154	32x320	
3231233	71x360		3231155	44x320	
3231234	83x360		3231156	53x320	
3231235	89x360		3231157	63x320	
3231236	102x360		3231158	71x320	
3231237	110x360		3231159	83x320	
3231238	120x360		3231160	89x320	
3231239	127x360		3231161	102x320	
3231240	132x360				
3231241	150x360				
3231242	159x360				
3231243	166x360				
3231244	180x360				
3231245	202x360				
3231246	220x360				
3231247	244x360				
3231248	300x360				



FOR DRY CUT / 金刚石切割刀 (干燥切割使用)

订货号	Ø x L	R
3231249	32x300	1/2" BSP MALE 公
3231250	44x300	
3231251	53x300	
3231252	63x300	
3231253	71x300	
3231254	83x300	
3231255	89x300	
3231256	102x300	
3231257	110x300	
3231258	120x300	
3231259	132x300	
3231260	150x300	



7.4 TOOLS FOR CONSTRUCTION & FOR WOOD 建筑工具、木工工具

FIXED BRACKET / (电动超强力旋转切割钻) 固定托架

订货号	对应的切割钻	重量 (公斤)
COD		Kg.
3231280	PERFOMATIC-205	22
	PERFOMATIC-255	
	PERFOMATIC-300	



90° RECLINABLE BRACKET / (电动超强力旋转切割钻) 固定托架, 可左右斜倚90度

订货号	对应的切割钻	重量 (公斤)
COD		Kg.
3231281	PERFOMATIC-205	35
	PERFOMATIC-255	
	PERFOMATIC-300	



VACUUM BASE / 真空座

订货号	对应的切割钻	订货号	订货号	重量 (公斤)
COD				Kg.
3231282	PERFOMATIC-205	3231296	3231297	6,5
	PERFOMATIC-255			
	PERFOMATIC-300			



EXTENSION / 延长杆

COD	A-B	Ø x L	重量 (公斤)
			Kg.
3231283	1.1/4" UNC	40x150	1,0
3231284		40x210	1,3
3231285	1/2" BSP	30x200	0,8
3231286		30x260	1,1



HANDLE / 手柄

COD		重量 (公斤)
		Kg.
3231287	PERFOMATIC-80	0,7
	PERFOMATIC-102	



THREAD CONNECTION ADAPTOR / 螺纹连接器

COD	A-B	重量 (公斤)
		Kg.
3231288	* 1.1/4" UNC - 1/2" BSP	0,4

* Female / 母 - Female / 母

COD	A-B	重量 (公斤)
		Kg.
3231289	* 1.1/4" UNC - 1/2" BSP	0,4

* Female / 母 - Male / 公



ELECTROHYDRAULIC REBAR CUTTERS / 电动 液压 钢筋切断机

REBARMATIC - 16 PORTABLE 电动液压钢筋切断机 (便携式, 带电池)

订货号 电压 切割直径 额定功率 割刀 (2件套) 重量 (公斤)

COD	V	CAP	W		
3232001	110-240V	Ø4-Ø16mm	690	3232111	5,6



Technical specification / 技术规格

Capacity / 切割钢筋管径范围	4mm-16mm
Cutting speed / 切割速度	3 sg (16mm)
Revolving head / 旋转刀头	360°
Battery / 电池	Ni-Mh DC 18V 3Ah
Included batteries / 包含电池	2 pcs
Electrohydraulic system / 电动液压系统	●
Case dimensions / 外壳尺寸	415x390x135mm
Metallic case / 金属壳	●
Blade set / 刀片组套	3232111



REBARMATIC - 16 电动液压钢筋切断机

订货号 电压 切割直径 额定功率 割刀 (2件套) 重量 (公斤)

COD	V	CAP	W		
3232002	230	Ø4-Ø16mm	690	3232112	8
3232003	110				



Technical specification / 技术规格

Capacity / 切割钢筋管径范围	4mm-16mm
Cutting speed / 切割速度	3 sg (16mm)
Electrohydraulic system / 电动液压系统	●
Case dimensions / 外壳尺寸	460x150x115mm
Metallic case / 金属壳	●
Blade set / 刀片组套	3232112



REBARMATIC - 22 电动液压钢筋切断机

订货号 电压 切割直径 额定功率 割刀 (2件套) 重量 (公斤)

COD	V	CAP	W		
3232004	230	Ø4-Ø22mm	850	3232113	12
3232005	110				

Technical specification / 技术规格

Capacity / 切割钢筋管径范围	4mm-22mm
Cutting speed / 切割速度	3 sg (22mm)
Electrohydraulic system / 电动液压系统	●
Case dimensions / 外壳尺寸	420x130x150mm
Metallic case / 金属壳	●
Blade set / 刀片组套	3232113



BEFORE / 切割前



AFTER / 切割后



7.4 TOOLS FOR CONSTRUCTION & FOR WOOD 建筑工具、木工工具

CUT-OFF MACHINE / 型材切割机

订货号	砂轮直径	电压	功率	转速/分钟	重量	孔径: 25.4 毫米(1寸)
COD	Ø	V	W	R.P.M.	Kg.	
3234001	355 毫米	230V	2300	3900	19	3234801
3234002	(14寸)	110V				

砂轮转速:3,900 转/分钟, 马达空转:12,000 转/分钟 (注:广州仓库长期充足库存)
体积(长×宽×高) 460×280×600 毫米, 电源线 2.5 米



CE *G12

BENCH BRICKS CUT-OFF MACHINE / 座椅式 瓷砖切割机

订货号	砂轮直径	最大切割尺寸	电压	功率	转速/分钟	重量
COD	Ø	CAP	V	W	R.P.M.	Kg.
3234003	355	255x406x127	230	1650	3500	21
3234004			110			

WATER-COOLED / 水冷系统



CE *G12

BRICKS CUT-OFF SAW / 瓷砖切割机

订货号	砂轮直径	最大切割尺寸	电压	功率	转速/分钟	重量
COD	Ø	CAP	V	W	R.P.M.	Kg.
3234005	355	255x406x127	230	1650	3500	11
3234006			110			

WATER-COOLED / 水冷系统



CE *G12

TOOLS FOR WOOD / 木工工具

FIRMER CHISELS / 木工凿

Precision machined steel blade / 精密的机加工钢刃

COD	长度	重量	数量	数量
3210100	6mm	130	12	1
3210101	8mm	135		
3210102	10mm	140		
3210103	12mm	145		
3210104	14mm	150		
3210105	15mm	155		
3210106	16mm	160		
3210107	18mm	170		
3210108	20mm	175		
3210109	22mm	180		
3210110	25mm	190		
3210111	30mm	200		
3210112	32mm	210		
3210113	35mm	220		

DIN 5139

TITACROM® BMAT



3210120	6mm	130	12	1
3210121	8mm	135		
3210122	10mm	140		
3210123	12mm	145		
3210124	14mm	150		
3210125	15mm	155		
3210126	16mm	160		
3210127	18mm	170		
3210128	20mm	175		
3210129	22mm	180		
3210130	25mm	190		
3210131	30mm	200		
3210132	32mm	210		
3210133	35mm	220		

DIN 5139

TITACROM® BMAT



7.4

TOOLS FOR CONSTRUCTION & FOR WOOD

建筑工具、木工工具



FIRMER CHISELS / 木工凿

Precision machined steel blade / 精密的机加工钢刃

COD				
3210140	6mm	130		
3210141	8mm	135		
3210142	10mm	140		
3210143	12mm	145		
3210144	14mm	150		
3210145	15mm	155		
3210146	16mm	160		
3210147	18mm	170	12	1
3210148	20mm	175		
3210149	22mm	180		
3210150	25mm	190		
3210151	30mm	200		
3210152	32mm	210		
3210153	35mm	220		

DIN 5139

TITACROM® BIMAT



3210160	6mm	130		
3210161	8mm	135		
3210162	10mm	140		
3210163	12mm	145		
3210164	14mm	150		
3210165	15mm	155		
3210166	16mm	160		
3210167	18mm	170	12	1
3210168	20mm	175		
3210169	22mm	180		
3210170	25mm	190		
3210171	30mm	200		
3210172	32mm	210		
3210173	35mm	220		

DIN 5139



FIRMER CHISELS KITS / 木工凿 组套

TITACROM BIMAT 4 PCS.

4件

PCS.	COD:3210802
1	3210102 10mm
	3210103 12mm
	3210105 15mm
	3210107 18mm



TITACROM BIMAT 4 PCS.

4件

PCS.	COD:3210803
1	3210122 10mm
	3210123 12mm
	3210125 15mm
	3210127 18mm



TITACROM BIMAT 4 PCS.

4件

PCS.	COD:3210804
1	3210142 10mm
	3210143 12mm
	3210145 15mm
	3210147 18mm



4 PCS.

4件

PCS.	COD:3210805
1	3210162 10mm
	3210163 12mm
	3210165 15mm
	3210167 18mm



7.4 TOOLS FOR CONSTRUCTION & FOR WOOD 建筑工具、木工工具

JACK PLANES / 木工刨

COD	← L →	gr.		
3210180	250mm	1,5	1	3210185
3210181	350mm	2,0		



CLAMPS / 夹钳

MOD. G G型夹钳

COD	A MAX mm	B mm	最大承受压力 *Kgf	gr.		
3210200	50	30	120	195	6	-
3210201	75	52	150	700		
3210202	100	60	255	900	4	
3210203	150	75	355	1600	3	
3210204	200	83	400	1900		

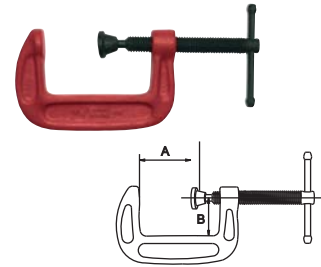

*Kgf: maximum pressure resistance/ 最大承受压力

MOD. F F型夹钳

COD	A MAX mm	B mm	最大承受压力 *Kgf	gr.			
3210210	150	50	225	450	6	-	
3210211	200			600			
3210212	250	80	360	1000			
3210213	300			1150			
3210214	350	120	600	1300			2
3210215	400			1600			
3210216	450			1800			
3210217	500			2000			
3210218	550			2200			
3210219	600			2700			
3210220	1000		3000				

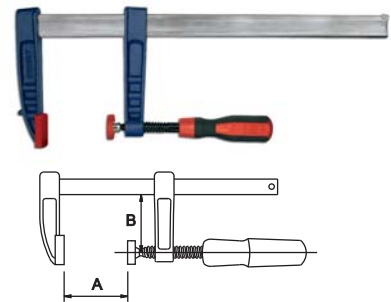

*Kgf: maximum pressure resistance/ 最大承受压力

FORGED / 锻造夹钳

COD	A MAX mm	B mm	C mm	D mm	最大承受压力 *Kgf	gr.	
3210250	160	80	7,5	15,5	255	600	6
3210251	200					640	
3210252	250					700	
3210253	300					750	
3210254	400					800	
3210255	200					100	
3210256	250	900					
3210257	300	950					
3210258	400	1000					
3210259	500	800					
3210260	200	120	10,5	21,5	400		900
3210261	250					1100	
3210262	300					1200	
3210263	400					1300	
3210264	500					1400	
3210265	600					1600	
3210266	800					1800	
3210267	1000					2000	
3210268	1200					2200	

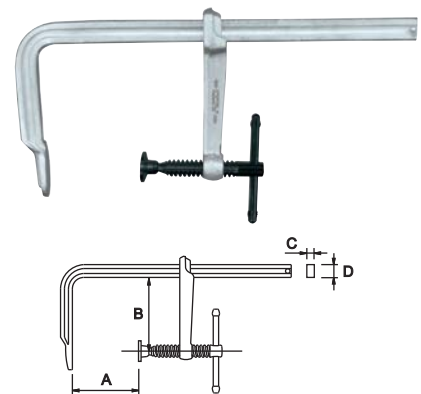

*Kgf: maximum pressure resistance/ 最大承受压力