

4.6



**SCREWDRIVERS / 螺丝刀**



Medal, International Inventors Competition, Paris 2007  
法国巴黎雷平国际发明展大奖 2007

**1.** Oversized ergonomic & anti-slippery handles offer optimal grip for avoiding slippage.  
大尺寸人体工程学防滑手柄，提供最优的握感。

**2.** Its exclusive chrome-molybdenum-vanadium alloy enables 30% higher tightening torque than traditional screwdrivers.  
独特的铬钼钒合金，比传统螺丝刀提高30%的紧固力。

**3.** The innovative “non-slip” anti-slippery and magnetic tip system allows an easier and safer positioning of the screwdriver, avoiding undesired slides.  
创新的“无滑”模式和磁刀头系统，令螺丝刀易于安全定位，避免滑位。

**4.** Go-through bar enables hammering on the Masterpunch screwdriver’s upper side.  
穿透式的刀杆，允许直接锤打在Masterpunch螺丝刀上面。



**5.** Type and size double marking of easy and efficient identification of the screwdriver to be used.  
螺丝刀类别和尺寸双标刻，使用时更易于迅速识别螺丝刀。

**6.** Hexagonal bar screwdrivers available for strong tightening with wrenches.  
带有六角位的螺丝刀，可配合扳手的强大扭力来操作。

**7.** Go-through hole in the handle enables tommy bar using.  
手柄上的横穿孔，适于螺丝旋棒的穿插操作。

**8.** Patented.  
奥戈工具的技术专利。

### SLOTTED SCREDDRIVER TORQUE POWER TESTING TOOL / 一字螺丝刀 扭矩测试工具

COD	L mm
3061000	140mm



# 4.6 SCREWDRIVERS / 螺丝刀



## MASTERTORK / 专利防滑手柄

### SLOTTED / 一字螺丝刀

订货号	刀口宽度	刀口厚度	刀杆直径	刀杆长度	刀柄长度	总长度	刀柄直径	磁性夹	
MM公制	A	B	Ø1(mm)	L1	L2	L	Ø2(mm)		
3062100	3	0,5	3	80	85	165	26	16	●
3062101	4	0,8	4	100	105	185	26	16	●
3062102	5,5	1	5	125	115	205	34	8	●
3062103	6,5	1,2	6	150	115	230	36	8	●
3062104	8	1,6	7	200	130	240	40	6	●
3062105	8	1,6	7	200	130	265	40	6	●
3062106	8	1,6	7	200	130	280	40	6	●
3062107	8	1,6	7	200	130	330	40	6	●
3062111	9,5	1,6	8	250	130	380	40	6	●
3062108	10	2	10	250	130	380	40	6	●
3062109	12	2	10	250	130	380	40	6	●
3062112	13	2,5	10	250	130	380	40	6	●
3062110	14	2,5	10	250	130	380	40	6	●



NON-SLIP ANTISLIIPPY MAGNETIC TIP  
无滑 防滑 磁性刀头



专利技术 防滑手柄

DIN 5265

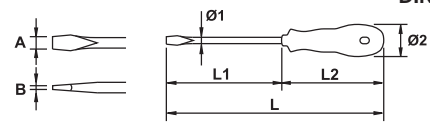

订货号	刀口宽度	刀口厚度	刀杆直径	刀杆长度	刀柄长度	总长度	刀柄直径	磁性夹	
INCH.英制	A	B	Ø1(mm)	L1	L2	L	Ø2(mm)		
3066100	1/8"	0,02"	3	3"	85	165	26	16	●
3066101	5/32"	0,032"	4	4"	105	185	26	16	●
3066102	7/32"	0,04"	5	5"	115	205	34	8	●
3066103	1/4"	0,046"	6	6"	115	230	36	8	●
3066104	1/4"	0,046"	6	6"	115	240	36	8	●
3066105	1/4"	0,046"	6	6"	115	265	36	8	●
3066106	5/16"	0,063"	7	8"	130	280	40	6	●
3066107	5/16"	0,063"	7	8"	130	330	40	6	●
3066108	3/8"	0,063"	8	8"	130	380	40	6	●
3066109	25/64"	0,08"	10	10"	130	380	40	6	●
3066110	15/32"	0,08"	10	10"	130	380	40	6	●
3066111	1/2"	0,098"	10	10"	130	380	40	6	●
3066112	9/16"	0,098"	10	10"	130	380	40	6	●

订货号	刀口宽度	刀口厚度	六角1	六角2	刀杆长度	刀柄长度	总长度	刀柄直径	磁性夹	
MM公制	A	B	HEX 1(mm)	HEX 2(mm)	L1	L2	L	Ø1(mm)		
3062113	4	0,8	4	-	100	85	185	26	16	●
3062114	5,5	1	5	-	125	105	230	34	8	●
3062115	6,5	1,2	6	11	150	115	240	36	8	●
3062116	8	1,6	8	11	150	115	280	36	8	●
3062117	10	1,6	8	11	200	130	330	40	6	●
3062118	12	2	10	16	250	130	380	40	6	●
3062119	14	2,5	10	16	250	130	380	40	6	●

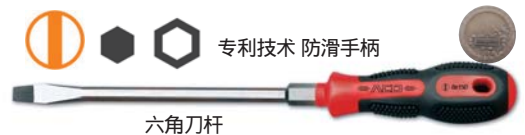

六角刀杆

DIN 5265

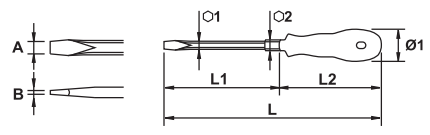

订货号	刀口宽度	刀口厚度	六角1	六角2	刀杆长度	刀柄长度	总长度	刀柄直径	磁性夹	
INCH.英制	A	B	HEX 1(mm)	HEX 2(mm)	L1	L2	L	Ø1(mm)		
3066124	5/32"	0,032"	4	-	4"	85	185	26	16	●
3066125	7/32"	0,04"	5	-	5"	105	230	34	8	●
3066126	1/4"	0,046"	6	11	6"	115	240	36	8	●
3066127	5/16"	0,046"	6	11	6"	115	280	36	8	●
3066128	5/16"	0,046"	6	11	6"	115	280	36	8	●
3066128	25/64"	0,063"	8	11	8"	130	330	40	6	●
3066129	15/32"	0,08"	10	16	10"	130	380	40	6	●
3066130	9/16"	0,098"	10	16	10"	130	380	40	6	●

### ELECTRICIAN / 电工一字螺丝刀

订货号	刀口宽度	刀口厚度	刀杆直径	刀杆长度	刀柄长度	总长度	刀柄直径	磁性夹	
MM公制	A	B	Ø1(mm)	L1	L2	L	Ø2(mm)		
3062120	2,5	0,4	2,5	75	160	160	26	16	●
3062121	3	0,5	3	60	85	145	26	16	●
3062122	3	0,5	3	100	105	185	26	16	●
3062123	4	0,8	4	125	125	230	34	8	●
3062124	4	0,8	4	150	105	255	34	8	●
3062128	4	0,8	4	300	105	405	34	8	●
3062125	5,5	1	5,5	150	105	255	34	8	●
3062129	5,5	1	5,5	300	105	405	34	8	●
3062126	6,5	1,2	6,5	150	115	265	36	6	●
3062127	8	1,2	8	175	130	305	40	6	●



专利技术 防滑手柄

DIN 5265

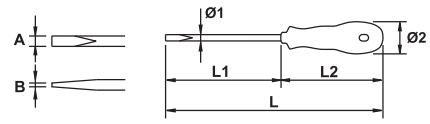

订货号	刀口宽度	刀口厚度	刀杆直径	刀杆长度	刀柄长度	总长度	刀柄直径	磁性夹	
INCH.英制	A	B	Ø1(mm)	L1	L2	L	Ø2(mm)		
3066142	3/32"	0,016"	2,5	3"	85	160	26	16	●
3066143	1/8"	0,02"	3	2"	85	145	26	16	●
3066144	1/8"	0,02"	3	4"	105	185	26	16	●
3066145	5/32"	0,032"	4	5"	125	230	34	8	●
3066146	5/32"	0,032"	4	6"	125	255	34	8	●
3066147	5/32"	0,032"	4	12"	105	405	34	8	●
3066148	7/32"	0,04"	5,5	6"	105	255	34	8	●
3066149	7/32"	0,04"	5,5	12"	105	405	34	8	●
3066150	1/4"	0,046"	6,5	6"	115	265	36	6	●
3066151	5/16"	0,046"	8	7"	130	305	40	6	●



# 4.6 SCREWDRIVERS / 螺丝刀

## PHILIPS 十字

刀口尺寸	刀杆直径	刀杆长度	刀柄长度	总长度	刀柄直径	磁性夹			
	$\varnothing 1(\text{mm})$	$L_1$	$L_2$	$L$	$\varnothing 2(\text{mm})$				
3062138	PH-0	3	60	85	145	26	16	1	●
3062139	PH-1	5	100	105	205	34	8	1	●
3062136			300		405				
3062140	PH-2	6	125	115	240	36	6	-	●
3062137			300		415				
3062141	PH-3	8	150	130	280	40	-	-	-
3062142	PH-4	10	200	130	330	40	-	-	-

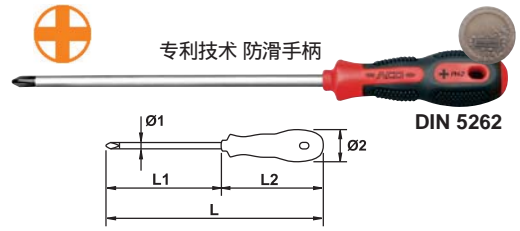

刀口尺寸	刀杆直径	刀杆长度	刀柄长度	总长度	刀柄直径	磁性夹				
	HEX 1(mm)	HEX 2(mm)	$L_1$	$L_2$	$L$	$\varnothing 1(\text{mm})$				
3062144	PH-1	5	8	100	105	205	8	8	1	●
3062145	PH-2	6	11	125	115	240	11	6	1	-
3062146				150		280				
3062147	PH-4	10	16	200	130	330	16	-	-	-

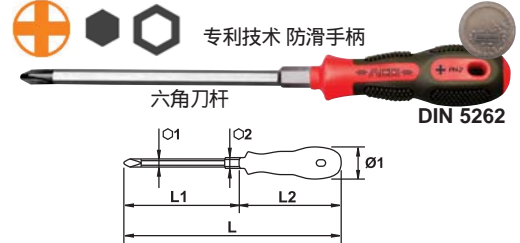

## POZIDRIV 米字

刀口尺寸	刀杆直径	刀杆长度	刀柄长度	总长度	刀柄直径	磁性夹			
	$\varnothing 1(\text{mm})$	$L_1$	$L_2$	$L$	$\varnothing 2(\text{mm})$				
3062156	PZ-0	3	60	85	145	26	16	1	●
3062157	PZ-1	5	100	105	205	34	8	1	●
3062154					405				
3062158	PZ-2	6	125	115	240	36	6	-	●
3062155					300				
3062159	PZ-3	8	150	130	280	40	-	-	-
3062160	PZ-4	10	200	130	330	40	-	-	-

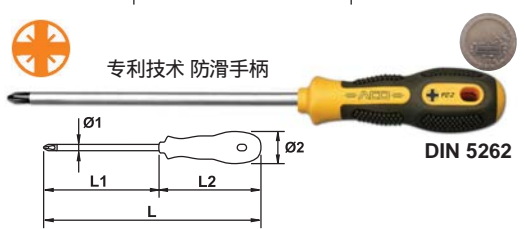

刀口尺寸	六角1	六角2	刀杆长度	刀柄长度	总长度	刀柄直径	磁性夹		
	HEX 1(mm)	HEX 2(mm)	$L_1$	$L_2$	$L$	$\varnothing 1(\text{mm})$			
3062162	PZ-1	5	8	100	105	205	34	8	1
3062163	PZ-2	6	11	125	115	240	36	6	-
3062164				150		278			
3062165	PZ-4	10	16	200	128	328	40	-	-



## TORX 星形

刀口尺寸	刀杆直径	刀杆长度	刀柄长度	总长度	刀柄直径	磁性夹			
	$\varnothing 1(\text{mm})$	$L_1$	$L_2$	$L$	$\varnothing 2(\text{mm})$				
3062174	T-6	3	50	85	135	26	16	1	●
3062175	T-7								
3062176	T-8								
3062177	T-9								
3062178	T-10								
3062179	T-15	4	100	105	205	34	8	-	●
3062180	T-20								
3062181	T-25	5	115	115	240	36	6	-	●
3062182	T-27								
3062183	T-30	6	125	115	240	36	6	-	●
3062184	T-40								
3062185	T-45	8	150	130	280	40	6	-	-
3062186	T-50								
3062187	T-6	10	175	130	305	40	6	-	-
3062188	T-7								

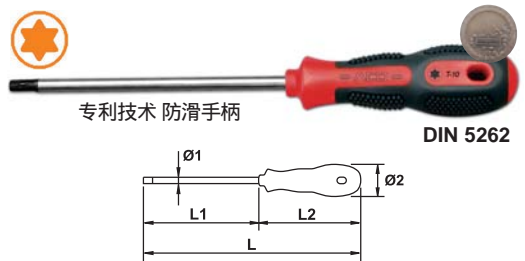

## TAMPER TORX 空心星形

刀口尺寸	刀杆直径	刀杆长度	刀柄长度	总长度	刀柄直径	磁性夹			
	$\varnothing 1(\text{mm})$	$L_1$	$L_2$	$L$	$\varnothing 2(\text{mm})$				
3062187	TT-6	3	50	85	135	26	16	1	●
3062188	TT-7								
3062189	TT-8								
3062190	TT-9								
3062191	TT-10								
3062192	TT-15	4	100	105	205	34	8	-	●
3062193	TT-20								
3062194	TT-25	5	115	115	240	36	6	-	●
3062195	TT-27								
3062196	TT-30	6	125	115	240	36	6	-	●
3062197	TT-40								
3062198	TT-45	8	150	130	280	40	6	-	-
3062199	TT-50								

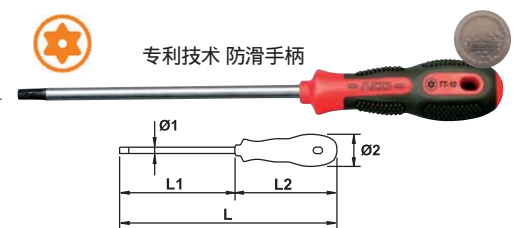

# 4.6 SCREWDRIVERS / 螺丝刀



## BALL TIP / 六角球头

六角尺寸	刀杆长度	刀柄长度	总长度	刀柄直径	磁性夹			
MM公制	HEX 1(mm)	L <sub>1</sub> (mm)	L <sub>2</sub> (mm)	L(mm)	Ø1(mm)			
3062201	2,5	75	85	160	26	16	1	●
3062202	3							
3062203	4			185				●
3062204	5	100		205	34			
3062205	6	125	105	230	36	8		
3062206	8							
3062207	10	150	130	280	40	6	-	

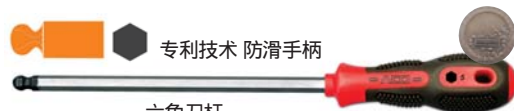

六角刀杆

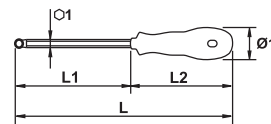

六角尺寸	刀杆长度	刀柄长度	总长度	刀柄直径	磁性夹			
INCH.英制	HEX 1	L <sub>1</sub> (mm)	L <sub>2</sub> (mm)	L(mm)	Ø1(mm)			
3066163	3/32"	3"	85	160	26	16	1	●
3066164	1/8"							
3066165	5/32"	4"		185				●
3066166	3/16"			205	34			
3066167	1/4"	5"	105	230	36	8		
3066168	5/16"							
3066169	25/64"	6"	130	280	40	6	-	

## ROBERTSON 内四角

刀杆直径	刀柄长度	刀柄长度	总长度	刀柄直径	磁性夹					
mm	Ø1(mm)	L <sub>1</sub> (mm)	L <sub>2</sub> (mm)	L(mm)	Ø2(mm)					
3062230	1	2,4	4	100	85	185	26	16	1	●
3062231	2	2,8	5	125	105	230	34	8		●
3062232	3	3,4	6	150	115	265	36	6		●



专利技术 防滑手柄

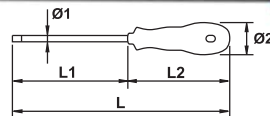

## STUBBY / 短柄螺丝刀

刀口宽度	刀口厚度	刀杆直径	刀杆长度	刀柄长度	总长度	刀柄直径	磁性夹		
MM公制	A	B	Ø1(mm)	L <sub>1</sub> (mm)	L <sub>2</sub> (mm)	L(mm)	Ø2(mm)		
3062235	5,5	1,2	5,5	25	60	85	40	20	1



专利技术 防滑手柄

刀口宽度	刀口厚度	刀杆直径	刀杆长度	刀柄长度	总长度	刀柄直径	磁性夹		
INCH.英制	A	B	Ø1(mm)	L <sub>1</sub> (mm)	L <sub>2</sub> (mm)	L(mm)	Ø2(mm)		
3062234	7/32"	0,046"	5,5	1"	60	85	40	20	1

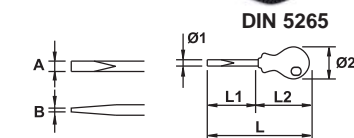

DIN 5265

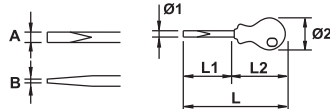

十字刀口	米字刀口	刀杆直径	刀杆长度	刀柄长度	总长度	刀柄直径	磁性夹		
Ø1(mm)	Ø1(mm)	L <sub>1</sub> (mm)	L <sub>2</sub> (mm)	L(mm)	Ø2(mm)				
3062236	PH-1	-	5						
3062237	PH-2	-	6						
3062238	-	PZ-1	5	25	60	85	40	20	1
3062239	-	PZ-2	6						



DIN 5262

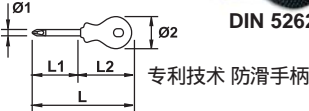

专利技术 防滑手柄

## SOCKET SCREWDRIVER / 套筒螺丝刀

套筒尺寸	套筒外径	刀杆直径	刀杆长度	刀柄长度	总长度	刀柄直径	磁性夹	
MM公制	Ø1(mm)	Ø2(mm)	L <sub>1</sub> (mm)	L <sub>2</sub> (mm)	L(mm)	Ø3(mm)		
3062250	4	8						
3062251	5	8,5	5	150	105	255	34	8
3062252	5,5							
3062253	6	10	6	160	115	275	36	
3062254	7	11				290		
3062255	8							
3062256	9	14	8					1
3062257	10	15						
3062258	11							
3062259	12	17	9	175	130	305	40	6
3062260	13	19						
3062261	14	20						



专利技术 防滑手柄

套筒尺寸	套筒外径	刀杆直径	刀杆长度	刀柄长度	总长度	刀柄直径	磁性夹	
INCH.英制	Ø1(mm)	Ø2(mm)	L <sub>1</sub> (mm)	L <sub>2</sub> (mm)	L(mm)	Ø3(mm)		
3066183	5/32"	8						
3066184	3/16"	8,5	5	6"	105	255	34	8
3066185	7/32"							
3066186	1/4"	10	6		115	275	36	
3066187	9/32"	11				290		
3066188	5/16"							
3066189	11/32"	14	8					1
3066190	25/64"	15						
3066191	27/64"	17	9	7"	130	305	40	6
3066192	15/32"							
3066193	1/2"	19						
3066194	9/16"	20						

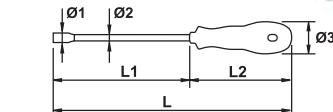

# 4.6 SCREWDRIVERS / 螺丝刀

## T - MASTERTORK T形两用螺丝刀

### HEXAGONAL ALLEN

MM公制	六角尺寸	长刀杆长度	长刀柄长度	长刀柄长度 (六角+柄)		总长	图标
	HEX t(mm)	L <sub>1</sub> mm	L <sub>2</sub> mm	L <sub>3</sub> mm	L mm		
3062271	2,5	125	40	60	165	16	1
3062272	3						
3062273	4						
3062274	5	150	50	80	200	8	
3062275	6						
3062276	8	175	65	100	240	6	
3062277	10						

INCH.英制	六角尺寸	长刀杆长度	长刀柄长度	长刀柄长度 (六角+柄)		总长	图标
	HEX t(mm)	L <sub>1</sub> mm	L <sub>2</sub> mm	L <sub>3</sub> mm	L mm		
3066206	3/32"	5"	40	60	165	16	1
3066207	1/8"						
3066208	5/32"						
3066209	3/16"	6"	50	80	200	8	
3066210	1/4"						
3066211	5/16"	7"	65	100	240	6	
3066212	25/64"						

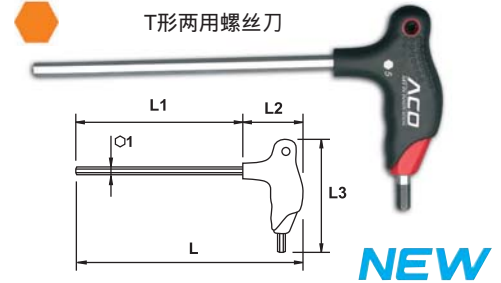

## TORX 星形

刀口尺寸 六角尺寸 长刀杆长度 长刀柄长度 (六角+柄) (长杆+柄)总长

COD	刀口尺寸	六角尺寸	长刀杆长度	长刀柄长度	长刀柄长度 (六角+柄)		总长	图标
		HEX t(mm)	L <sub>1</sub> mm	L <sub>2</sub> mm	L <sub>3</sub> mm	L mm		
3062281	T-6	3	125	40	60	165	16	1
3062282	T-7							
3062283	T-8							
3062284	T-9							
3062285	T-10							
3062286	T-15							
3062287	T-20	4						
3062288	T-25	4,5	150	50	80	200	8	
3062289	T-27	5,5						
3062290	T-30	6						
3062291	T-40	7	175	65	100	240	6	
3062292	T-45	8						
3062293	T-50	9						

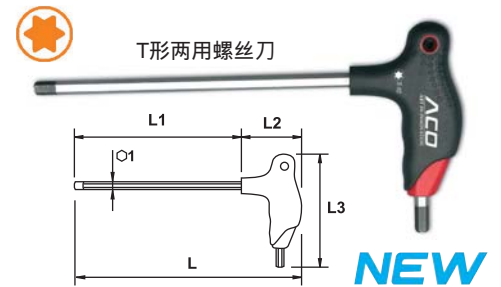

## SOCKET SCREWDRIVER / T型套筒螺丝刀

套筒尺寸 套筒外径 刀杆直径 刀杆长度 刀柄长度 横柄长度 (刀杆+柄)总长

MM公制	套筒尺寸	套筒外径	刀杆直径	刀杆长度	刀柄长度	横柄长度	(刀杆+柄)总长	图标
	Ø1(mm)	Ø2(mm)	L <sub>1</sub> mm	L <sub>2</sub> mm	L <sub>3</sub> mm	L mm		
3062296	5	8,5	5	150	50	80	200	1
3062297	6	10	6					
3062298	7	11	6					
3062299	8	13	8	175	65	100	240	
3062300	9	14						
3062301	10	15						
3062302	11	17	9	9	65	100	240	
3062303	12	17						
3062304	13	19	9	9	65	100	240	

INCH.英制	套筒尺寸	套筒外径	刀杆直径	刀杆长度	刀柄长度	横柄长度	(刀杆+柄)总长	图标
	Ø1(mm)	Ø2(mm)	L <sub>1</sub> mm	L <sub>2</sub> mm	L <sub>3</sub> mm	L mm		
3066327	5/16"	13	8	7" (178)	65	100	240	6
3066329	25/64"	15						
3066331	15/32"	17						

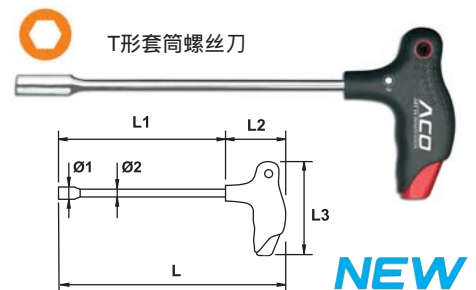

# 4.6 SCREWDRIVERS / 螺丝刀



## MASTERPUNCH ALL THROUGH 穿透式的刀杆，允许直接锤打在Masterpunch螺丝刀上面。通心可砸 螺丝刀

NON-SLIP ANTISLIPPERY MAGNETIC TIP / 防滑 防滑 磁性刀头



GO-THROUGH BAR ENABLES HAMMERING ON THE SCREWDRIVER'S UPPER SIDE 通心刀杆，允许锤子直接锤打在螺丝刀上面



### SLOTTED / 一字

MM公制	刀口宽度 A	刀口厚度 B	六角1 HEX 1(mm)	六角2 HEX 2(mm)	刀杆长度 L1	刀柄长度 L2	总长度 L	刀柄直径 Ø1(mm)	磁性夹	包装
3062311	6,5		6		125	110	235	35		
3062312	8	1,2	8	11	150	120	270	39	6	1
3062313	10	1,6	8	11	175	120	295	39	6	1

INCH.英制	刀口宽度 A	刀口厚度 B	六角1 HEX 1(mm)	六角2 HEX 2(mm)	刀杆长度 L1	刀柄长度 L2	总长度 L	刀柄直径 Ø1(mm)	磁性夹	包装
3062314	1/4"		6		5"	110	235	35		
3062315	5/16"	0,046"	8	11	6"	120	270	39	6	1
3062316	25/64"	0,063"	8	11	7"	120	295	39	6	1



六角刀杆

通心可砸 螺丝刀

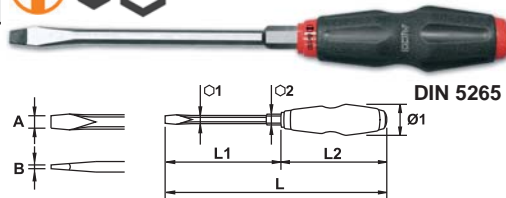

DIN 5265

### PHILIPS 十字

COD	刀口尺寸	六角1 HEX 1(mm)	六角2 HEX 2(mm)	刀杆长度 L1	刀柄长度 L2	总长度 L	刀柄直径 Ø1(mm)	磁性夹	包装
3062319	PH-2	6	11	125	110	235	35	6	1
3062320	PH-3	8	11	150	120	270	39	6	1

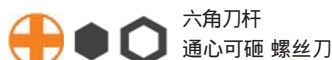

六角刀杆

通心可砸 螺丝刀



DIN 5262

### POZIDRIV 米字

COD	刀口尺寸	六角1 HEX 1(mm)	六角2 HEX 2(mm)	刀杆长度 L1	刀柄长度 L2	总长度 L	刀柄直径 Ø1(mm)	磁性夹	包装
3062325	PZ-2	6	11	125	110	235	35	6	1
3062326	PZ-3	8	11	150	120	270	39	6	1

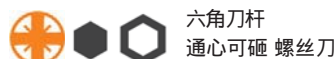

六角刀杆

通心可砸 螺丝刀

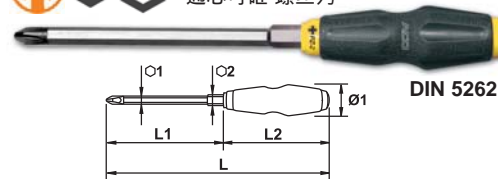

DIN 5262

### SET 通心可砸 螺丝刀 组套 (10件套)

订货号 包含产品

3062331	一字 (公制) : 3062311, 3062312, 3062313
	(英制) : 3062314, 3062315, 3062316
	十字 : 3062319, 3062320
	米字 : 3062325, 3062326

### ROTORK / 经典型手柄

#### SLOTTED / 一字

MM公制	刀口宽度 A	刀口厚度 B	刀杆直径 Ø1(mm)	刀杆长度 L1	刀柄长度 L2	总长度 L	刀柄直径 Ø2(mm)	磁性夹
3063104	3	0,5	3	80		155	22	16
3063105	4	0,8	4		75	175		
3063106				100		205		
3063107	5,5	1	5		105	230	31	
3063108				125		255		
3063109	6,5	1,2	6		118	268	35	8
3063110				150		288		
3063111	8		7		118	318	35	8
3063112				200		365		
3063113	10	1,6	8		115	365	35	6
3063114	12	2	10		115	365	35	6
3063114	14	2,5	10		115	365	35	6

INCH.英制	刀口宽度 A	刀口厚度 B	刀杆直径 Ø1(mm)	刀杆长度 L1	刀柄长度 L2	总长度 L	刀柄直径 Ø2(mm)	磁性夹
3066228	1/8"	0,02"	3	3"	75	155	22	16
3066229	5/32"	0,032"	4	4"	75	175		
3066230				100		205		
3066231	7/32"	0,04"	5	5"	105	230	31	
3066232				125		255		
3066233	1/4"		6		118	268	35	8
3066234		0,046"	7	6"	118	288		
3066235	5/16"		8		118	318	35	8
3066236		0,063"	8	8"	118	318	35	6
3066237	25/64"	0,063"	8		118	318	35	6
3066237	15/32"	0,080"	10	10"	115	365	35	6
3066238	9/16"	0,098"	10	10"	115	365	35	6

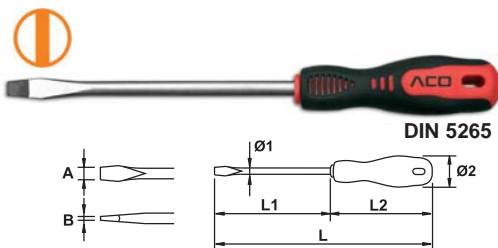

DIN 5265



# 4.6 SCREWDRIVERS / 螺丝刀

## ROTORK / 经典型手柄

MM公制	刀口宽度 A	刀口厚度 B	六角1 HEX 1(mm)	六角2 HEX 2(mm)	刀杆长度 L <sub>1</sub> (mm)	刀柄长度 L <sub>2</sub> (mm)	总长度 L(mm)	刀柄直径 Ø1(mm)	磁性夹
3063121	4	0,8	4	-	100	75	175	22	16
3063122	5,5	1	5	-	125	105	230	31	8
3063123	6,5	1,2	6	-	150	115	265	35	6
3063124	8	1,6	8	11	200	115	315	35	6
3063125	10	2	10	-	250	115	365	35	6
3063126	12	2,5	12	-	300	115	415	35	6
3063127	14	3	14	-	350	115	465	35	6

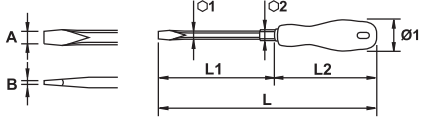

## ELECTRICIAN / 电工一字螺丝刀

MM公制	刀口宽度 A	刀口厚度 B	刀杆直径 Ø1(mm)	刀杆长度 L <sub>1</sub> (mm)	刀柄长度 L <sub>2</sub> (mm)	总长度 L(mm)	刀柄直径 Ø2(mm)	磁性夹
3063135	2,5	0,4	2,5	60	75	135	22	16
3063136	3	0,5	3	100	75	175	22	16
3063137	4	0,8	4	125	105	230	31	8
3063138	5	1	5	150	105	255	31	8
3063139	6	1,2	6	175	115	290	35	6
3063140	8	1,6	8	200	115	315	35	6
3063141	10	2	10	250	115	365	35	6
3063142	12	2,5	12	300	115	415	35	6
3063143	14	3	14	350	115	465	35	6
3063144	16	3,5	16	400	115	515	35	6

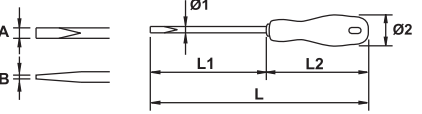

INCH.英制	刀口宽度 A	刀口厚度 B	刀杆直径 Ø1(mm)	刀杆长度 L <sub>1</sub> (mm)	刀柄长度 L <sub>2</sub> (mm)	总长度 L(mm)	刀柄直径 Ø2(mm)	磁性夹
3066278	3/32"	0,016"	2,5	2"	75	135	22	16
3066279	1/8"	0,02"	3	4"	75	175	22	16
3066280	5/32"	0,032"	4	6"	105	200	31	8
3066281	3/16"	0,04"	5	8"	105	255	31	8
3066282	1/4"	0,046"	6	6"	115	255	35	6
3066283	5/16"	0,063"	8	7"	115	290	35	6
3066284	3/8"	0,08"	10	8"	115	315	35	6
3066285	1/2"	0,098"	12	10"	115	365	35	6
3066286	5/8"	0,125"	14	12"	115	415	35	6
3066287	3/4"	0,156"	16	14"	115	465	35	6

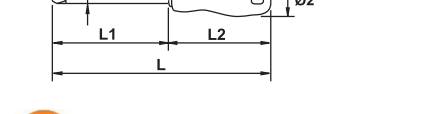
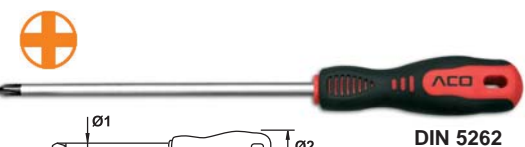

## PHILIPS 十字

刀口尺寸 Ø1(mm)	六角1 HEX 1(mm)	六角2 HEX 2(mm)	刀杆长度 L <sub>1</sub> (mm)	刀柄长度 L <sub>2</sub> (mm)	总长度 L(mm)	刀柄直径 Ø2(mm)	磁性夹
3063147	PH-0	3	60	75	135	22	16
3063148	PH-1	4	100	105	205	31	8
3063149	PH-2	5	125	115	265	35	6
3063150	PH-3	6	150	115	265	35	6
3063151	PH-4	10	200	115	315	35	6

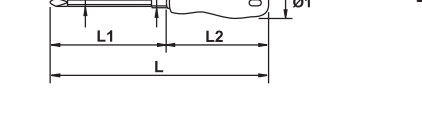

刀口尺寸 HEX 1(mm)	六角1 HEX 1(mm)	六角2 HEX 2(mm)	刀杆长度 L <sub>1</sub> (mm)	刀柄长度 L <sub>2</sub> (mm)	总长度 L(mm)	刀柄直径 Ø1(mm)	磁性夹	
3063160	PH-1	5	-	100	105	205	31	8
3063161	PH-2	6	-	125	115	265	35	6
3063162	PH-3	8	11	150	118	268	35	6
3063164	PH-4	10	-	200	115	315	35	6

## POZIDRIV 米字

刀口尺寸 Ø1(mm)	刀杆直径 Ø1(mm)	刀杆长度 L <sub>1</sub> (mm)	刀柄长度 L <sub>2</sub> (mm)	总长度 L(mm)	刀柄直径 Ø2(mm)	磁性夹	
3063167	PZ-0	3	60	75	135	22	16
3063168	PZ-1	5	100	105	205	31	8
3063169	PZ-2	6	125	115	265	35	6
3063170	PZ-3	8	150	118	268	35	6
3063171	PZ-4	10	200	115	315	35	6

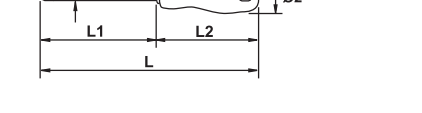

# 4.6 SCREWDRIVERS / 螺丝刀



## POZIDRIV 米字

刀口尺寸 六角1 六角2 刀杆长度 刀柄长度 总长度 刀柄直径

HEX 1(mm) HEX 2(mm) L<sub>1</sub> L<sub>2</sub> L Ø1(mm)

3063177	PZ-1	5	-	100	115	215	8	1	●
3063178	PZ-2	6		125		240			●
3063179	PZ-3	8	11	150		265	35	6	●
3063180	PZ-4			200		315			-

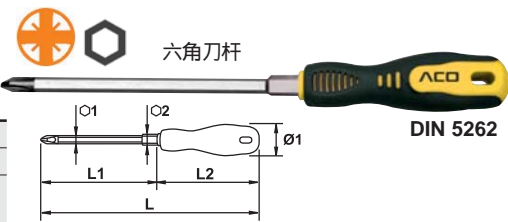

## TORX 星形

刀口尺寸 刀杆直径 刀杆长度 刀柄长度 总长度 刀柄直径

Ø1(mm) L<sub>1</sub> L<sub>2</sub> L Ø2(mm)

3063187	T-6	3	50	75	125	22	16	1	●
3063188	T-7								●
3063189	T-8								●
3063190	T-9								●
3063191	T-10	4	75	105	150	31	8	1	●
3063192	T-15								●
3063193	T-20				175				●
3063194	T-25	5	100	105	205	31	8	1	●
3063195	T-27	6	115	105	220	31	8	1	●
3063196	T-30				230				●
3063197	T-40	7	125	105	240	31	8	1	●
3063198	T-45	8	150	115	265	35	6	1	●
3063199	T-50	10	175	115	290	35	6	1	●

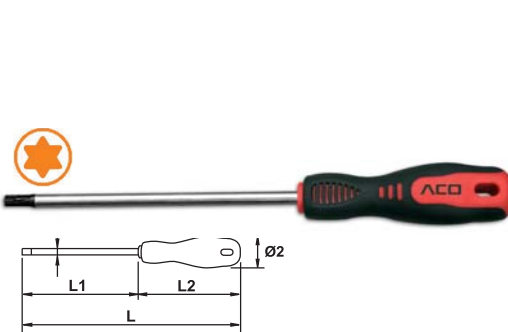

## TAMPER TORX 空心星形

刀口尺寸 刀杆直径 刀杆长度 刀柄长度 总长度 刀柄直径

Ø1(mm) L<sub>1</sub> L<sub>2</sub> L Ø2(mm)

3066565	TT-6	3	50	75	125	22	16	1	●
3066566	TT-7								●
3066567	TT-8								●
3066568	TT-9								●
3066569	TT-10	4	75	105	150	31	8	1	●
3066572	TT-15								●
3066573	TT-20				175				●
3066574	TT-25	5	100	105	205	31	8	1	●
3066594	TT-27	6	115	105	220	31	8	1	●
3066595	TT-30				230				●
3066596	TT-40	7	125	105	240	31	8	1	●
3066597	TT-45	8	150	115	265	35	6	1	●
3066598	TT-50	10	175	115	290	35	6	1	●

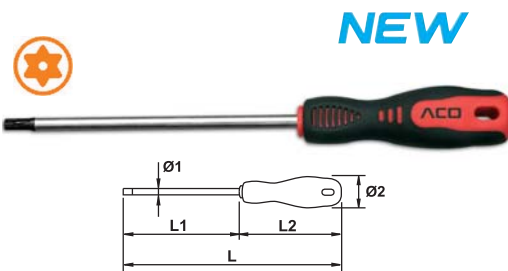

## BALL TIP / 六角球头

六角尺寸 刀杆长度 刀柄长度 总长度 刀柄直径

HEX 1(mm) L<sub>1</sub> L<sub>2</sub> L Ø1(mm)

3063208	2,5	75	75	150	22	16	1	●
3063209	3			175				●
3063210	4	100	105	205	31	8	1	●
3063211	5			230				●
3063212	6	125	105	230	31	8	1	●
3063213	8			265				●
3063214	10	150	115	265	35	6	1	●

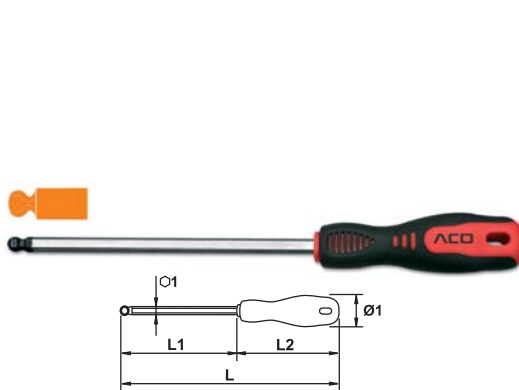

## INCH. 英制

六角尺寸 刀杆长度 刀柄长度 总长度 刀柄直径

HEX 1 L<sub>1</sub> L<sub>2</sub> L Ø1(mm)

3066300	1/8"	3"	75	150	22	16	1	●
3066301	5/32"			175				●
3066302	3/16"	4"	105	205	31	8	1	●
3066303	1/4"			230				●
3066304	5/16"	5"	115	230	31	8	1	●
3066305	25/64"	6"	115	268	35	6	1	●

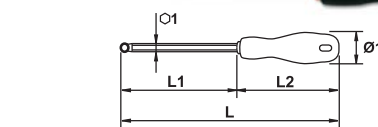

## ROBERTSON / 四方头

刀杆直径 刀杆长度 刀柄长度 总长度 刀柄直径

Ø1(mm) L<sub>1</sub> L<sub>2</sub> L Ø2(mm)

3063224	1	2,4	5	100	75	175	22	16	1	●
3063225	2	2,8		125	105	230	31	8	1	●
3063226	3	3,4	6	150		255		6		●

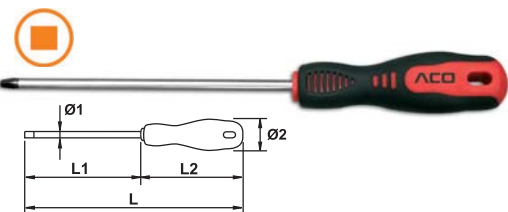

# 4.6 SCREWDRIVERS / 螺丝刀

## STUBBY / 短杆螺丝刀

订货号 刀口宽度 刀口厚度 刀杆直径 刀杆长度 刀柄长度 总长度 刀柄直径  
**MM公制** → A → B → Ø1(mm) → L<sub>1</sub> → L<sub>2</sub> → L → Ø2(mm)

3063227	5,5	1,2	5,5	25	60	85	31	20	1
---------	-----	-----	-----	----	----	----	----	----	---

订货号 刀口宽度 刀口厚度 刀杆直径 刀杆长度 刀柄长度 总长度 刀柄直径  
**INCH.英制** → A → B → Ø1(mm) → L<sub>1</sub> → L<sub>2</sub> → L → Ø2(mm)

3063228	1"	0,046"	5,5	1"	60	85	31	20	1
---------	----	--------	-----	----	----	----	----	----	---

十字刀口 米字刀口 刀杆直径 刀杆长度 刀柄长度 总长度 刀柄直径  
**COD** →  →  → Ø1(mm) → L<sub>1</sub> → L<sub>2</sub> → L → Ø2(mm)

3063240	PH-1	-	5	25	60	85	31	20	1
3063241	PH-2	-	5,5						
3063242	-	PZ-1	5						
3063243	-	PZ-2	6						

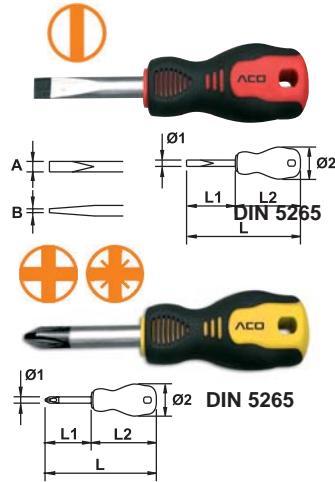

## ACCESSORIES

### MAGNETIC SCREW HOLDERS / 磁性螺丝夹

COD	Ø	
3066801	2-3,2mm	3062120, 3062121, 3062122, 3066142, 3066143, 3066144, 3062138, 3062156, 3062174, 3062175, 3062176, 3062177, 3062178, 3062188, 3062189, 3062190, 3062191, 3062201, 3062202, 3066163, 3066164, 3063135, 3073322, 3073325, 3066278, 3066279, 3066280, 3063147, 3063167, 3063187, 3063188, 3063189, 3063208, 3263209, 3066300.
3066802	4,5-5,2mm	3062100, 3062101, 3062123, 3062124, 3062128, 3062139, 3062137, 3062179, 3062180, 3062181, 3062182, 3250850, 3250851, 3250858, 3250868, 3250869, 3250870, 3250871, 3250872, 3062157, 3062154, 3062230, 3062231, 3062203, 3063104, 3063105, 3063138, 3063139, 3063140, 3063141, 3250930, 3250931, 3250932, 3063149, 3063168, 3063177, 3250863, 3063189, 3063190, 3063191, 3063192, 3063193, 3063194, 3063210, 3063211, 3063224, 3063225.
3066803	5,5-6mm	3062125, 3062129, 3066148, 3066149, 3252063, 3252064, 3250852, 3062144, 3062183, 3062158, 3062155, 3062232, 3063142, 3250933, 3063160, 3250940.
3066804	6-6,35mm	3062140, 3062137, 3250853, 3250854, 3250778, 3250859, 3250873, 3250874, 3063169, 3063150, 3063178, 3063195, 3063212, 3063226, 3250934, 3250941, 3250864.

**NEW**



超强磁性，有效防止螺丝掉落。与铁质螺丝配合，正向使用，吸紧螺丝与刀头，高效工作。与不锈钢螺丝配合，反向使用，弹性胶套夹紧螺丝，安全拧紧与安装。



To work with ferrous screws  
与铁质螺丝配合使用



To work with stainless steel screws  
与不锈钢螺丝配合使用



\*Suitable for 50mm length bits  
\*适用于50毫米长的刀头

Supports up to 2 kg weight  
超强磁性。最大支持2公斤



\*To see the available bits check the bits chapter 4.7 of ACO general catalog  
\*具体的刀头类别和尺寸请查看4.7章。

# 4.6 SCREWDRIVERS / 螺丝刀



## MICROTRONIC

微电子行业

仪表螺丝刀 (带旋转帽)



## SLOTTED / 一字

MM公制	A	B	Ø1(mm)	L <sub>1</sub> (mm)	L <sub>2</sub> (mm)	L(mm)	Ø2(mm)	Box	Disp
3064006	2	0,4	3	50	95	145	21	10	1
3064007				75					
3064008	3	0,5	4	75	95	170	21	10	1
3064009	4	0,8							



DIN 6265

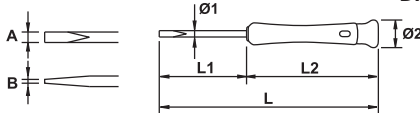

INCH.英制	A	B	Ø1(mm)	L <sub>1</sub> (mm)	L <sub>2</sub> (mm)	L(mm)	Ø2(mm)	Box	Disp
3064089	5/64"	0,016"	3	2"	95	145	21	10	1
3064090				3"					
3064091	1/8"	0,02"	4	3"	95	170	21	10	1
3064092	5/32"	0,03"							

## PHILIPS 十字

COD



COD	Ø1(mm)	L <sub>1</sub> (mm)	L <sub>2</sub> (mm)	L(mm)	Ø2(mm)	Box	Disp	
3064010	PH-00	2	50	95	145	21	10	1
3064011	PH-0	3	75	95	170	21	10	1
3064012	PH-1	4						

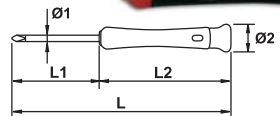

DIN 6262

## POZIDRIV 米字

COD



COD	Ø1(mm)	L <sub>1</sub> (mm)	L <sub>2</sub> (mm)	L(mm)	Ø2(mm)	Box	Disp	
3064013	PZ-0	3	50	95	145	21	10	1
3064014	PZ-1	4	75	95	170	21	10	1

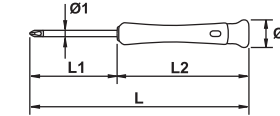

DIN 6262

## TORX 星形



COD	Ø1(mm)	L <sub>1</sub> (mm)	L <sub>2</sub> (mm)	L(mm)	Ø2(mm)	Box	Disp	
3064015	T-6	2	50	95	145	21	10	1
3064016	T-7	3						
3064017	T-8	3	75	95	170	21	10	1
3064018	T-9							
3064019	T-10	4	75	95	170	21	10	1
3064020	T-15							
3064021	T-20							

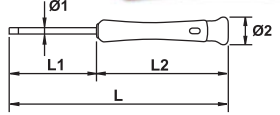

## TAMPER TORX 空心星形

COD



COD	Ø1(mm)	L <sub>1</sub> (mm)	L <sub>2</sub> (mm)	L(mm)	Ø2(mm)	Box	Disp	
3064026	TT-6	2	50	95	145	21	10	1
3064027	TT-7	3						
3064028	TT-8	3	75	95	170	21	10	1
3064029	TT-9							
3064030	TT-10	4	75	95	170	21	10	1
3064031	TT-15							
3064032	TT-20							

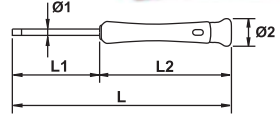

## HEXAGONAL BALL POINT / 六角球头

MM公制

HEX 1(mm)

MM公制	HEX 1(mm)	L <sub>1</sub> (mm)	L <sub>2</sub> (mm)	L(mm)	Ø1(mm)	Box	Disp
3064042	1,5	50	95	145	21	10	1
3064043	2						
3064044	2,5	60	95	155	21	10	1
3064045	3						

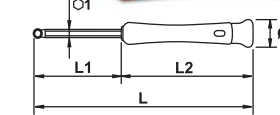

INCH.英制	HEX 1(mm)	L <sub>1</sub> (mm)	L <sub>2</sub> (mm)	L(mm)	Ø1(mm)	Box	Disp
3064104	1/16"	2"	95	145	21	10	1
3064105	5/64"						
3064106	3/32"						
3064107	1/8"						



# 4.6 SCREWDRIVERS / 螺丝刀

## 1000V MICROTRONIC ELECTRICIAN /

1000V绝缘 微电子 电工螺丝刀

SLOTTED / 一字

订货号 刀口宽度 刀口厚度 直径1 直径2 刀杆长度 刀柄长度 总长度 刀柄端直径

COD	A	B	Ø1(mm)	Ø2(mm)	L1	L2	L	Ø3(mm)	gr.	box	bag
3251506	1,5	0,23	1,5	3,1	40		140				
3251507	1,8	0,3	1,8	3,4	60	100	160	19	10	1	
3251508	2		2	3,6							
3251509	2,5	0,4	2,5	4,1	75		175				
3251511	3	0,5	3	4,6							

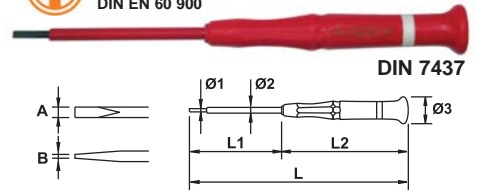

PHILIPS / 十字

订货号 刀口类型 直径1 直径2 刀杆长度 刀柄长度 总长度 刀柄端直径

COD	Ø1(mm)	Ø2(mm)	L1	L2	L	Ø3(mm)	gr.	box	bag
3251512	PH-00	2,5	4,1	75	100	175	19	10	1
3251513	PH-0	3	4,6						

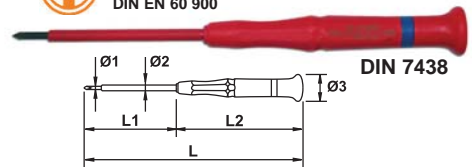

ELECTROSTATIC DISCHARGE / 防静电螺丝刀

ELECTRICIAN / 电工一字螺丝刀

MM公制 A B Ø1(mm) L1 L2 L Ø2(mm) gr. box bag

COD	A	B	Ø1(mm)	L1	L2	L	Ø2(mm)	gr.	box	bag
3064050	1	0,2		40		140	14			
3064051	1,5	0,3	2				16			
3064052	2						17	10		
3064053	2,5	0,4	2,5	60	100	160	19			
3064054	3	0,5	3				21			
3064055	3,5	0,6	3,5				24			
3064056	4	0,7	4							



INCH.英制 A B Ø1(mm) L1 L2 L Ø2(mm) gr. box bag

COD	A	B	Ø1(mm)	L1	L2	L	Ø2(mm)	gr.	box	bag
3064079		3/64"				140	14			
3064080	5/64"	1/16"	2				16			
3064081		5/64"					17	10		
3064082	3/32"	3/32"	2,5	2"	100	160	19			
3064083	1/8"	1/8"	3				21			
3064084	9/64"	9/64"	3,5				24			
3064085	5/32"	5/32"	4							

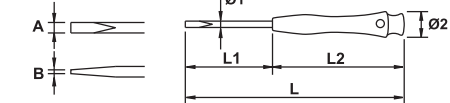

PHILIPS 十字

COD Ø1(mm) Ø2(mm) L1 L2 L Ø2(mm) gr. box bag

COD	Ø1(mm)	Ø2(mm)	L1	L2	L	Ø2(mm)	gr.	box	bag
3064057	2,5	PH00	60	100	160	16	17	10	-
3064058	3,0	PH0					19		1
3064059	4,0	PH1					24		

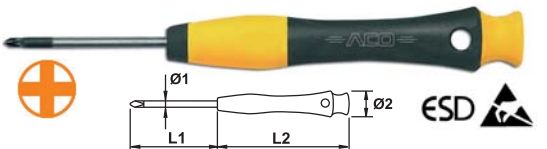

POZIDRIV 米字

COD Ø1(mm) Ø2(mm) L1 L2 L Ø2(mm) gr. box bag

COD	Ø1(mm)	Ø2(mm)	L1	L2	L	Ø2(mm)	gr.	box	bag
3064063	3,0	PZ0	60	100	160	16	19	10	1
3064064	4,0	PZ1					24		

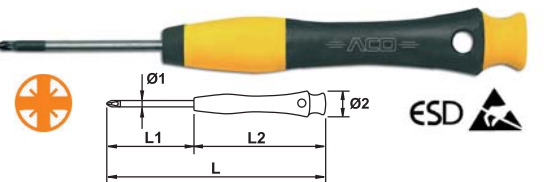

TORX 星形

COD Ø1(mm) Ø2(mm) L1 L2 L Ø2(mm) gr. box bag

COD	Ø1(mm)	Ø2(mm)	L1	L2	L	Ø2(mm)	gr.	box	bag
3064066		T4					14	10	-
3064067	2,5	T5	40	100	140	16	14		
3064068		T6							

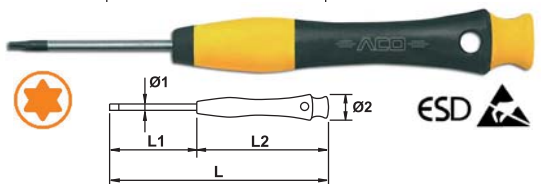

TAMPER TORX 空心星形

COD Ø1(mm) Ø2(mm) L1 L2 L Ø2(mm) gr. box bag

COD	Ø1(mm)	Ø2(mm)	L1	L2	L	Ø2(mm)	gr.	box	bag
3064072	2,5	TT-7	40		140	15			
3064073		TT-8		100		16		10	
3064074	3,0	TT-9	60		160	19			1
3064075		TT-10							

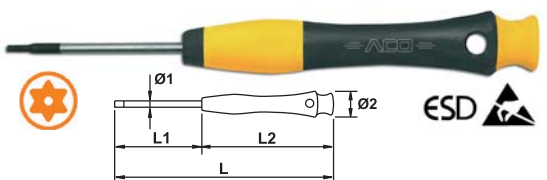

# 4.6 SCREWDRIVERS / 螺丝刀

TOOL SET PACKING / 组套包装方式 (4种)



A包装: 透明塑料盒



B包装: 吸塑盒



C包装: 拉链纤维袋



D包装: 插扣纤维袋

## SET MASTERTORK 螺丝刀组套 (专利防滑手柄)

5 PCS / 5件套 (一字、十字)

	pcs.		
A包装:3065011 B包装:3065012 C包装:3065013	1	3x100	⊖
		4x125	
		5,5x150	⊕
		PH1	
		PH2	

5 PCS / 5件套 (十字)

	pcs.		
A包装:3067009 B包装:3067010 C包装:3067011	1	PH0	⊕
		PH1	
		PH2	
		PH3	
		PH4	

5 PCS / 5件套 (米字)

	pcs.		
A包装:3067012 B包装:3067013 C包装:3067014	1	PZ0	⊗
		PZ1	
		PZ2	
		PZ3	
		PZ4	

6 PCS / 6件套 (一字、十字)

	pcs.		
A包装:3065014 B包装:3065015 C包装:3065016	1	2,5x60	⊖
		3x100	
		4x125	
		5,5x150	⊕
		PH1	
		PH2	

6 PCS / 6件套 (一字)

	pcs.		
A包装:3067000 B包装:3067001 C包装:3067002	1	3x80	⊖
		4x100	
		5,5x125	
		6,5x150	
		8x200	
		10x200	

6 PCS / 6件套 (一字、米字)

	pcs.		
A包装:3067018 B包装:3067019 C包装:3067020	1	4x100	⊖
		5,5x100	
		6,5x125	
		PZ1	⊗
		PZ2	
		PZ3	

6 PCS / 6件套 (一字、十字)

	pcs.		
A包装:3067021 B包装:3067022 C包装:3067023	1	4x100	⊖
		5,5x125	
		6,5x150	
		PH1	⊕
		PH2	
		PH3	

7 PCS / 7件套 (星形)

	pcs.		
A包装:3067024 B包装:3067025 C包装:3067026	1	T6	⊛
		T8	
		T10	
		T15	
		T20	
		T25	
		T30	

7 PCS / 7件套 (星形)

	pcs.		
A包装:3067027 B包装:3067028 C包装:3067029	1	T10	⊛
		T15	
		T20	
		T25	
		T27	
		T30	
		T40	

8 PCS / 8件套 (一字、十字、米字)

	pcs.		
A包装:3065017 B包装:3065018 C包装:3065019	1	3x100	⊖
		4x125	
		5,5x125	
		6,5x150	⊕
		PH0	
		PH1	
		PZ1	
		PZ2	

8 PCS / 8件套 (一字)

	pcs.		
A包装:3067003 B包装:3067004 C包装:3067005	1	3x80	⊖
		4x100	
		5,5x100	
		5,5x125	
		6,5x125	
		8x150	
		8x200	
		10x200	

8 PCS / 8件套 (一字、十字)

	pcs.		
A包装:3067015 B包装:3067016 C包装:3067017	1	3x80	⊖
		4x100	
		5,5x125	
		6,5x150	⊕
		PH0	
		PH1	
		PH2	
		PH3	

10 PCS / 10件套 (一字)

	pcs.		
D包装:3067031	1	3x80	⊖
		4x100	
		5,5x100	
		6,5x125	
		8x150	
		8x200	
		10x200	
		12x250	
		13x250	
		14x250	

10 PCS / 10件套 (一字)

	pcs.		
D包装:3067032	1	1/8"x3"	⊖
		5/32"x4"	
		7/32"x4"	
		1/4"x5"	
		5/16"x6"	
		3/8"x8"	
		25/64"x8"	
		15/32"x10"	
		1/2"x10"	
		9/16"x10"	

11 PCS / 11件套 (六角套筒)

	pcs.		
D包装:3067033	1	5/32"	⊙
		3/16"	
		7/32"	
		1/4"	
		9/32"	
		5/16"	
		11/32"	
		25/64"	
		15/32"	
		1/2"	
		9/16"	



# 4.6 SCREWDRIVERS / 螺丝刀

## SET MASTERTORK 螺丝刀组套 (专利防滑手柄)

12 PCS / 12件套 (空心星形)

D包装:3067036	1	pcs.	TT7	
		TT8		
		TT9		
		TT10		
		TT15		
		TT20		
		TT25		
		TT27		
		TT30		
		TT40		
		TT45		
		TT50		





12 PCS / 12件套 (六角套筒)

D包装:3067037	1	pcs.	4	
		5		
		5,5		
		6		
		7		
		8		
		9		
		10		
		11		
		12		
		13		
		14		

13 PCS / 13件套 (星形)





D包装:3067038	1	pcs.	T6	
		T7		
		T8		
		T9		
		T10		
		T15		
		T20		
		T25		
		T27		
		T30		
		T40		
		T45		
		T50		

150 PCS / 150件套 (专利防滑手柄)

3067040	10	pcs.	5,5x100			
		6,5x125				
		8x150				
					3x60	
		3x100				
		4x125				
					5,5x150	
		6,5x150				
		3x100				
					PH0	
		PH1				
					PH2	
		PZ0				
		PZ1				
		PZ2				



56 PCS / 56件套

3067041	6	pcs.	5,5x100		
			6,5x125		
			8x150		
	5	6	4x125	5,5x150	
				4x125	
				PH1	
	5	6	PH2	PH1	
				PH2	
	6	5	PZ1	PZ1	
				PZ2	

## SET ROTORK 螺丝刀组套 (经典型手柄)

5 PCS / 5件套 (一字、十字)

A包装:3065041 B包装:3065042 C包装:3065043	1	pcs.	5,5x125	
		3x100		
		5x150		
		PH1		
		PH2		

5 PCS / 5件套 (一字)

A包装:3065044 B包装:3065045 C包装:3065046	1	pcs.	3x80	
		4x100		
		5,5x125		
		6,5x150		
		8x200		

5 PCS / 5件套 (十字)

A包装:3065050 B包装:3065051 C包装:3065052	1	pcs.	PH0	
		PH1		
		PH2		
		PH3		
		PH4		



5 PCS / 5件套 (米字)

A包装:3065053 B包装:3065054 C包装:3065055	1	pcs.	PZ0	
		PZ1		
		PZ2		
		PZ3		
		PZ4		

5 PCS / 5件套 (十字)

A包装:3067063 B包装:3067064 C包装:3067065	1	pcs.	PH0	
		PH1		
		PH2		
		PH3		
		PH4		



6 PCS / 6件套 (一字、十字)

A包装:3065059 B包装:3065060 C包装:3065061	1	pcs.	2,5x60			
		3x100				
		4x125				
					5x150	
		PH1				
		PH2				



6 PCS / 6件套 (一字)

A包装:3067060 B包装:3067061 C包装:3067062	1	pcs.	3x80	
		4x100		
		5,5x125		
		6,5x150		
		8x200		
		10x200		

6 PCS / 6件套 (一字、十字)

A包装:3067071 B包装:3067072 C包装:3067073	1	pcs.	4x100			
		5,5x125				
		6,5x150				
					PH1	
		PH2				
		PH3				

6 PCS / 6件套 (一字、米字)

A包装:3067068 B包装:3067069 C包装:3067070	1	pcs.	4x100			
		5,5x100				
		6,5x125				
					PZ1	
		PZ2				
		PZ3				

# 4.6 SCREWDRIVERS / 螺丝刀



## SET ROTORK 螺丝刀组套 (经典手柄)

7 PCS / 7件套 (星形)

A包装:3067074 B包装:3067075 C包装:3067076	1	pcs. T10	
		T15	
		T20	
		T25	
		T27	
		T30	
		T40	

7 PCS / 7件套 (星形)

A包装:3067077 B包装:3067078 C包装:3067079	1	pcs. T6	
		T8	
		T10	
		T15	
		T20	
		T25	
		T30	

8 PCS / 8件套 (一字、十字、米字)

A包装:3065062 B包装:3065063 C包装:3065064	1	pcs. 3x100	
		4x125	
		5,5x125	
		6,5x150	
		PH0	
		PH1	
		PZ1	
		PZ2	

8 PCS / 8件套 (一字)

A包装:3065068 B包装:3065069 C包装:3065070	1	pcs. 3x80	
		4x100	
		5,5x100	
		5,5x125	
		6,5x125	
		8x150	
		8x200	
		10x200	

8 PCS / 8件套 (一字)

A包装:3065071 B包装:3065072 C包装:3065073	1	pcs. 2,5x60	
		3x100	
		4x125	
		5x150	
		5x200	
		6x150	
		8x175	
		10x200	

8 PCS / 8件套 (一字、十字)

A包装:3067080 B包装:3067081 C包装:3067082	1	pcs. 3x80	
		4x100	
		5,5x125	
		6,5x150	
		PH0	
		PH1	
		PH2	
		PH3	

150 PCS / 150件套 (经典型)

3067092	10	pcs. 5,5x100	
		6,5x125	
		8x150	
		3x60	
		3x100	
		4x125	
		5x150	
		6x150	
		3x100	
		PH0	
		PH1	
		PH2	
		PZ0	
		PZ1	
PZ2			



MICROTRONIC 100 PCS / 100件套 (微电子)

3067094	5	pcs. 2x50	
		2x75	
		3x75	
		4x75	
		PH00	
		PH0	
		PH1	
		PZ0	
		PZ1	
		T6	
		T7	
		T8	
		T9	
		T10	
		T15	
		T20	
		1,5x50	
		2x50	
		2,5x50	
3x60			

MICROTRONIC 6 PCS / 6件套 (仪表螺丝刀)

3065076	1	pcs. 2x50	
		3x75	
		PH00	
		PH0	
		PZ0	
		PZ1	



MICROTRONIC 8 PCS / 8件套 (微电子)

3084034	1	pcs. 3104100	
		3081126	
		3081127	
		3081128	
		3081129	
		3081131	
		3064006	
		2x50	
		3064010	
		PH00	



MICROTRONIC 1000V 7 PCS / 7件套 (1000V绝缘 微电子螺丝刀)

3253283	1	pcs. 1,5x40	
		1,8x60	
		2x60	
		2,5x75	
		3x75	
		PH00	
		PH0	



# 4.6 SCREWDRIVERS / 螺丝刀

## CLASSIC 通用经典型 电笔

订货号	笔头	笔长	测试电压	重量 (克)		
COD			V			
3320606	3x65	140	100 - 250AC	20	12	1
3320607	4x100	190		35		
3320608	3,5X100		90-480AC	40		







## MAGNETIZER-DEMAGNETIZER / 加磁消磁器

用于给螺丝刀头或镊子尖加磁或消磁。将螺丝刀杆插入“+”号框内，螺丝刀头部立即感应到磁性，刀头可吸附螺钉。将螺丝刀杆插入“-”号框内，螺丝刀头即消磁，不再具备磁性。

COD			
3066000	80	12	1



## SCREW STRACTORS / 断螺钉取出器 (左旋)

COD	M					
3197080	3-6	50	2,6	3,9	2,5	5
3197081	6-8	55	3,0	4,3	3,0	10
3197082	8-11	65	4,0	6,5	4,5	20
3197083	11-14	75	4,5	7,5	6,0	30
3197084	14-18	85	7,0	11	8,0	50
3197085	18-25	90	9,0	15	11	100
3197086	25-35	95	9,5	19	14	150
3197087	>35	100	14	24	20	200

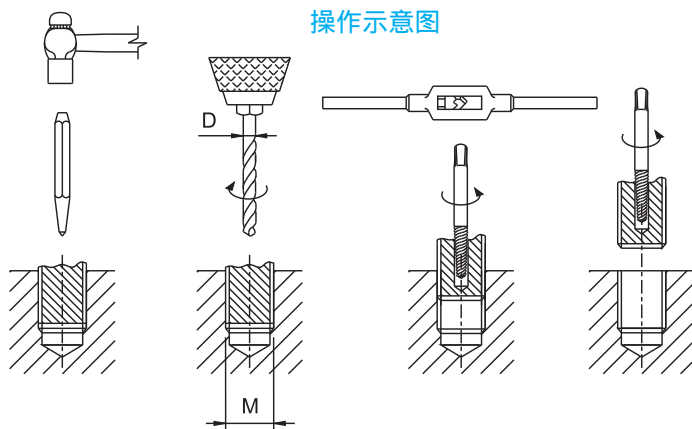
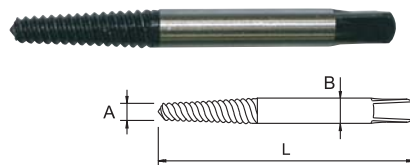

## SET 断螺钉取出器 组套

订货号	包含 Composition	件数 pcs.	
3197088	3197080, 3197081, 3197082 3197083, 3197084	5	100
3197089	3197080, 3197081, 3197082 3197083, 3197084, 3197085	6	200
3197090	3197080, 3197081, 3197082 3197083, 3197084, 3197085 3197086, 3197087	8	750

